

## U Series Needle Valve

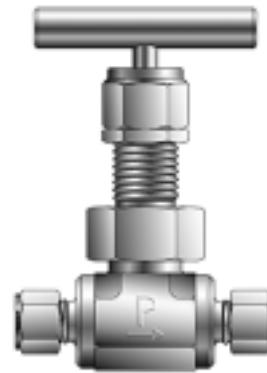

**Table I: Maximum Working Pressure and Temperature**

Valve Packing	Maximum Pressure and Temperature	Maximum Temperature and Pressure
Grafoil® Stem Packing	6000 psig at 70 °F 41.4 MPa at 21 °C	1545 psig at 1200 °F 10.7 MPa at 649 °C
PTFE Stem Packing	6000 psig at 70 °F 41.4 MPa at 21 °C	4280 psig at 450 °F 29.5 MPa at 204 °C

Refer to Parker U Series Needle Valve Maintenance Instructions (MI-104) when valve disassembly is required. Always consult your authorized Parker representative if questions arise. The arrow on the Valve Body indicates the normal direction of flow.

**Table II: Packing Nut  
Hex Wrench Sizes and Tightening Requirements**

Valve Size	Hex Wrench Size	PTFE Stem Packing	Grafoil® Stem Packing
U6 model	3/4 inch	125 in-lbs (14.1 N-m)	10.4 ft-lbs (37.3 N-m)
U12 model	15/16 inch	150 in-lbs (16.8 N-m)	33.3 ft-lbs (44.8 N-m)
U16 model	1-1/8 inch	50 ft-lbs (67.8 N-m)	50 ft-lbs (67.8 N-m)

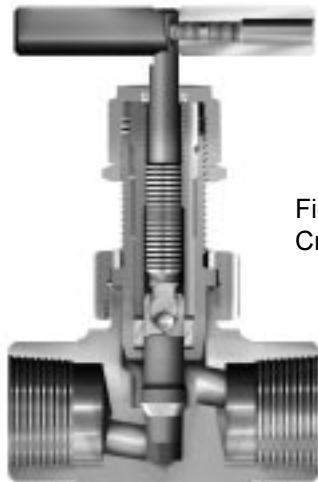

Figure 1: U Series Needle Valve  
Cross Sectional View

**Table III: Lock Nut  
Hex Wrench Sizes and Tightening Requirements**

Valve Size	Hex Wrench Size	Torque Requirement
U6 model	3/4 inch	125 in-lbs (14.1 N-m)
U12 model	15/16 inch	150 in-lbs (16.8 N-m)
U16 model	1 1/4 inch	150 in-lbs (16.8 N-m)

**Table IV: Bonnet Nut  
Hex Wrench Sizes and Tightening Requirements**

Valve Size	Hex Wrench	Torque Requirements
U6 model	15/16 inch	65 ft-lbs. (88 N-m)
U12 model	1-1/4 inch	75 ft-lbs. (101 N-m)
U16 model	1-1/2 inch	100 ft-lbs. (135 N-m)

**PANEL MOUNTED VALVES**

The panel must have a through-hole diameter of correct diameter. The maximum panel thickness is 1/4 inch (6.4 mm).

U6 model	41/64 inch (16.2 mm)
U12 model	53/64 inch (21.0 mm)
U16 model	1-1/64 inch (25.8 mm)

- Remove the Handle by unthreading the Set Screw in the side of the Handle with the following size allen wrench:
 

U6 model	3/32 inch
U12 model	3/32 inch
U16 model	1/8 inch
- Grip the Packing Nut with a wrench as listed in Table II. With another wrench (as listed in Table III), loosen the Lock Nut.
- Remove both the Packing Nut and the Lock Nut by unthreading until completely removed.
- Insert the Valve through the hole in the panel and assemble the Panel Nut onto the Bonnet finger-tight. For assembly, grip the large Bonnet Nut with a hex wrench as listed in Table IV and tighten the Panel Nut securely.
 

**CAUTION:** Do not grip the Valve Body or loosen the Bonnet Nut.
- Thread the Lock Nut onto the Bonnet. Thread the Packing Nut onto the Bonnet and tighten in accordance with Table II.
- Tighten the Lock Nut against the Packing Nut in accordance with Table III.
- Re-install the Handle with the Set Screw onto the Stem.

## VALVE CONNECTOR MAKE-UP INSTRUCTIONS

### MALE AND FEMALE PIPE PORTS

Wrench flats are provided on the Valve Body. It is recommended a smooth-jawed wrench or vise be used to grip the Valve Body.

1. On the male threaded part of the connection, apply a high quality pipe joint compound or PTFE tape made for this purpose. When PTFE tape is used, it is recommended two full turns of tape be applied. PTFE tape should not be overhanging or covering the first thread
2. Engage the Valve and the other component part together, until hand-tight.
3. With a proper wrench, holding both the Valve and the component part, continue to tighten to achieve a leak-tight joint.

### ULTRASEAL CONNECTIONS

1. Insert the proper O-Ring into the UltraSeal fitting's O-Ring groove. Position the UltraSeal gland sealing face against the O-Ring, and then advance the Nut to a finger-tight position.
2. A positive seal is obtained by advancing the Nut no less than 1/4 turn from the finger-tight position. Proper UltraSeal make-up is achieved when a sharp rise in required application torque occurs, which indicates proper seal face contact and O-Ring seal compression into the UltraSeal groove.

### VACUSEAL CONNECTIONS

1. A positive seal is obtained by advancing the Nut 1/8 turn from the finger-tight position.
2. A new gasket should be installed upon each fitting re-make to insure system pressure integrity.

### TUBE FITTING CONNECTIONS

1. Insert the tube into the Valve port until the tube bottoms out in the Valve Body. Care should be exercised to insure the tube is properly aligned with the Valve Body and port.
2. Normal make-up for US Customary port sizes 1 thru 3 (1/16 thru 3/16 inch) and SI port sizes 2 thru 4 (2 thru 4 mm) is 3/4 turn from finger tight. Normal make-up for US Customary port sizes 4 thru 16 (1/4 thru 1 inch) and SI port sizes 5 thru 25 (5 thru 25 mm) is 1 1/4 turn from finger tight. For larger port sizes consult Parker Ferrule Presetting Tool Instructions.

**PLEASE FOLLOW THE ABOVE DIRECTIONS FOR COUNTING THE NUMBER OF TURNS FOR PROPER FITTING MAKE-UP. DO NOT MAKE-UP TUBE FITTINGS BY TORQUE OR "FEEL". VARIABLES SUCH AS TUBING AND FITTING TOLERANCES, TUBE WALL THICKNESS, AND THE LUBRICITY OF NUT LUBRICANTS CAN RESULT IN AN IMPROPERLY ASSEMBLED TUBE FITTING CONNECTION.**

**A** -Two ferrule A-LOK®  
compression port



**Z** -Single ferrule CPI™  
compression port



**F** -ANSI/ASME B1.20.1  
Internal pipe threads



**V** -VacuSeal face  
seal port



**Q** -UltraSeal face  
seal port



**M** -ANSI/ASME B1.20.1  
External pipe threads



---

## **WARNING**

**FAILURE OR IMPROPER SELECTION OR IMPROPER USE OF THE PRODUCTS AND/OR SYSTEMS DESCRIBED HEREIN OR RELATED ITEMS CAN CAUSE DEATH, PERSONAL INJURY AND PROPERTY DAMAGE.**

This document and other information from Parker Hannifin Corporation, its subsidiaries and authorized distributors provide product and/or system options for further investigation by users having technical expertise. It is important that you analyze all aspects of your application and review the information concerning the product or system in the current product catalog. Due to the variety of operating conditions and applications for these products or systems, the user, through its own analysis and testing, is solely responsible for making the final selection of the products and systems and assuring that all performance, safety and warning requirements of the application are met.

The products described herein, including without limitation, product features, specifications, designs, availability and pricing, are subject to change by Parker Hannifin Corporation and its subsidiaries at any time without notice.

**ALL PARKER VALVES MUST PASS A RIGID OPERATIONAL AND LEAKAGE TEST BEFORE LEAVING THE FACTORY. IT IS RECOMMENDED AFTER ANY REASSEMBLY, THE VALVE SHOULD BE TESTED BY THE USER FOR OPERATION AND LEAKAGE. IF THESE INSTRUCTIONS ARE NOT FULLY COMPLIED WITH, THE REPAIRED PRODUCT MAY FAIL AND CAUSE DAMAGE TO PROPERTY OR INJURY TO PERSONS. PARKER HANNIFIN CANNOT ASSUME RESPONSIBILITY FOR PERFORMANCE OF A CUSTOMER SERVICED VALVE.**

